

# ABRASIVE TRIBOLOGICAL TESTING OF DIFFERENT HOT-DIP GALVANIZED MULTILAYERS

László Szabadi

Institute for Mechanical Engineering Technology, Faculty of Mechanical Engineering,  
Szent István University, Gödöllő,

**Abstract** One method for steel structures corrosion resistance is using hot-dip galvanizing process. Nowadays it is widely used in Europe considering its favourable characteristics. Lately beside the corrosion resistance demand of hot-dip galvanized coatings as a new requirement is wear resistance. The cause of this is more and more steel constructions are provided with zinc coatings as durable protection against corrosion. The industrial floor boards, agricultural walking grids get heavy abrasion effect. The abrasive wear resistance is a less tested, less known domain.

**Keywords** diffusion, abrasive wear, gradient material structure.

## 1. INTRODUCTION, APPLICATION FIELDS OF COATING HOT-DIP GALVANIZED, THEIR PRODUCING AND THE COATING CHARACTERISTICS.

The hot-dip galvanizing technology is used for durable resistance against of surfaces of iron- and steel constructions and of goods sold by the piece, its protection effect depends decisively on the thickness of a layer. Its main application fields suggested is the surface protection against atmospheric load in all corrosivity grades as well as to protect the metal structures of indoor ventilated spaces. Its application expands continuously because of its reliable protective effect, the process industrial-scale applicability, its comparatively high productivity and low need for human labor demand. Continually increasing proportion of steel constructions manufactured in Europe-yearly more than 6 million ton-are covered by coatings hot-dip galvanized. Nowadays the products get also mechanical loads beside corrosion effects at industrial filters, industrial, agricultural, public square pavement grids hot-dip galvanized meaning new and at the same time expanding application fields. At surfaces hot-dip galvanized exposed to abrasive wear, sand and breakstone spreading there is an application demand for today wear- and friction resistant coatings. Comparing test data regulated relating to wear resistance there are not available neither in technical literature nor in the data-base of companies producing and developing coatings. These data are indispensable to develop technology improving wear resistance.

Two basic groups developed hot-dip galvanizing (1). The most characteristic phase of individual processes are the dip into the metal bath exists at each group, however there are significant differences between individual solutions considering the preceding surface preparation and subsequent treatments. There is no difference between the two process groups considering the zinc-layer forming which takes place by the same physical-chemical processes. They so called continuous technologies belong to the first group, during which the product to be galvanized “as spliced” continuously with suitable speed passes through on the technological system.

The continuous broad strip-, narrow strip- and wire galvanizing processes have similar methods essentially. The strip surfaces are oxide relieved in a closed technological system, their materials are heated up then are guided into zinc-bath where the coat develops.

The so called periodic technologies belong to the second group. At there the products get treatment by individually or in groups. The surface is here also pre-treated then this is followed with hot-dip galvanizing. Covering steel constructions belong to this group, too.

The pure zinc is readily-formed and soft metal. The Zn hardness- 55-70HBS (2) is far below of the mild steel hardness -120HBS-, thus its wear resistance is also significantly smaller. In case of alloyed steels this difference can be still significantly greater. The structure of zinc-layer is determined decisively by the chemical composition and texture of steel base-metal, the zinc-bath temperature, the dip duration, the zinc-bath alloying elements, the surface condition and thickness of the workpiece as well drawing out speed and the lifting method of the workpiece to be coated (3). During dip-hot galvanizing an intermetallic, multi phase zinc layer develops on the products surfaces. The last step of technological treatment is the galvanizing when at about 450°C temperature the zinc atoms diffuse into the clean metal surface and produce atomic (cohesion) bond infiltrating into the metal-crystalline, namely they form an alloy with iron, on the zinc-iron boundary surface zinc rich Fe-crystallines

develop. This forms essentially the “adhesive-bridge” between the zinc coating and the iron plate. The further alloy layers are based on this which iron content decreases progressively to the outer layer and in case of optimal steel quality also cease to exist. The coating thickness is about 80-100 µm. Figure 1. shows the zinc layer structure.

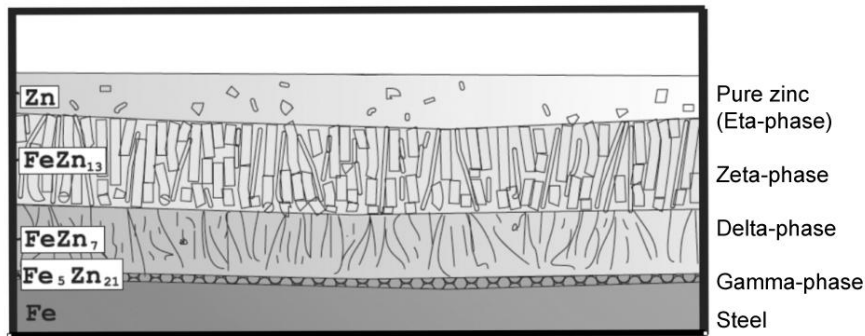

Figure 1. The zinc layer structure and the individual phases.

The gradient material structure developed during diffusion is not homogeneous, its composition changes in the function of thickness.

## 2. METHOD AND RESULTS

### 2.1. Specimens tested.

We have chosen S235JRG2 steel as specimen material used for abrasive tests, which is the most definite base metal for example of pavement grid. As this material is desoxidized with aluminium- and not with silicium – and the mechanism of layer developing is determined first of all by the amount of silicium to be in steel, therefore it can be hot-dip galvanizing outstandingly. We have taken into account at deciding the specimens dimension the tool form of the abrasion tester, as well as those positions and the geometrical dimension of the container containing the abrasive medium ensuring abrasion. Figure 2 shows the dimension of specimen galvanized.

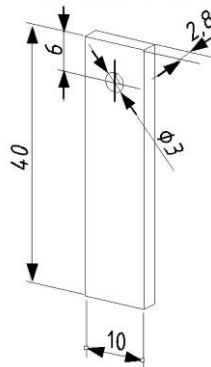

Figure 2. Specimen dimension.

Two types of coating were tested in the function of friction length, speed and pressure of abrasive medium.

- Technigalva: The determining components are the zinc (Zn), aluminium (Al), lead (Pb) and nickel (Ni) of the zinc-bath. The coating was made by dry periodic technology.
- Technigalva heat treated: Some part of the specimens were heat treated in order to the coating should have zinc-iron alloy phases in the total cross-section.

Figure 3. and 4. show the SEM-pictures made from coatings. Certain layers, phases can be separated very good in the thousand-fold magnification. We have also carried out EDS (Electron Detector System) tests.

The abrasion resistance of coatings depends on its hardness, therefore it is needed to measure the micro-hardness. The micro-hardness tests showed that the Techigalva coatings had 48HVM in average, while the heat treated coating had 106 HVM in average.

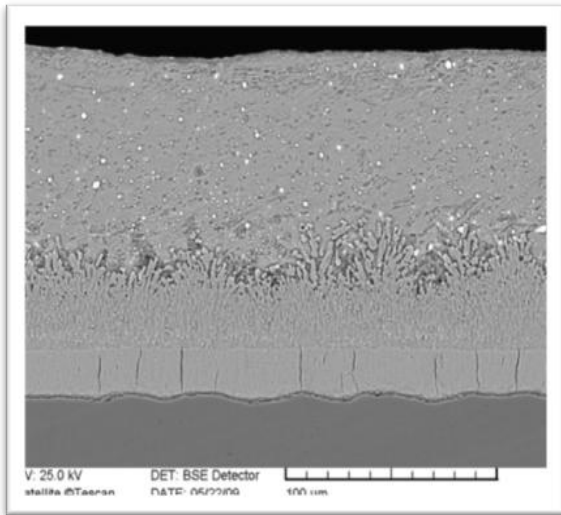

Figure 3. 1000X-magnification of Technigalva specimen zinc coating

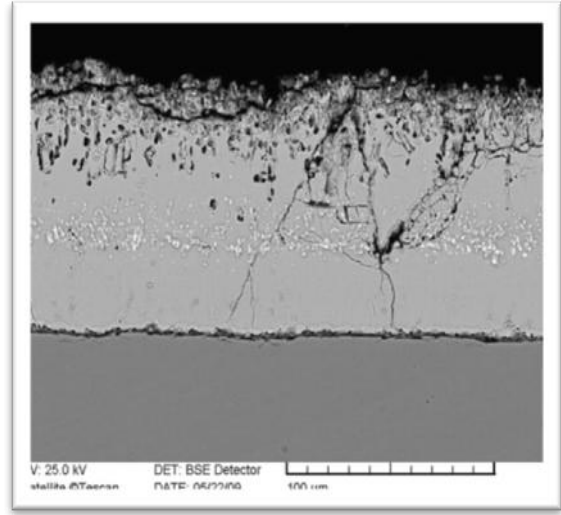

Figure 4. 1000X magnification of specimen heat treated zinc coating

## 2.2. Abrasion test with “sand-slurry” equipment

The “sand-slurry” principle is well known in the VI. test category of tribological modeling. Several versions are wide-spread but they agree that for example in a sand with grain composition given - as in abrasive medium – a specimen moves in circular orbit generally with speed given. Great number of specimens can be measured at the same time in abrasive medium given as well as it can be well define but beside in different conditions with the abrasion tester developed in the Institute for Mechanical Engineering Technology. The results got made possible the evaluation according to various standpoints, too. Figure 5. shows the abrasion tester developed.

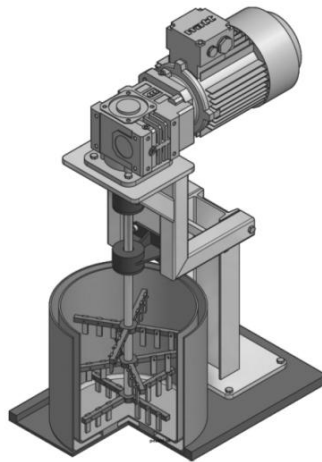

Figure 5. The abrasion with specimens mounted.

The electric motor shaft connects to a worm-gear which gear transmission in 22,58. The working shaft can be found at the exit side of the worm-gear on which 3 pcs. arm cross-clamps can be found – in different heights related to the base plate (Figure 6.)

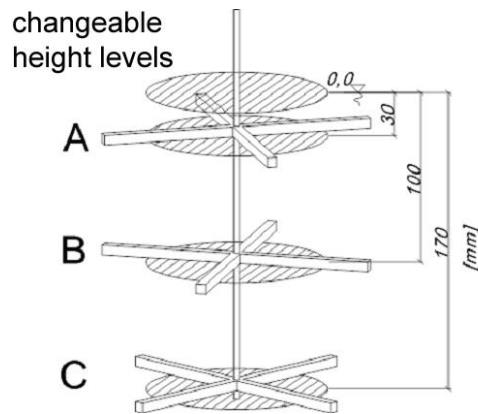

Figure 6. Specimens placed on three levels.

The specimens to be abraded can be fixed in suitable position on this. To one tool, to each arm 3 pcs. altogether 6-6 pcs. specimens can be fixed.

Important characteristic of the cross-clamps is that the specimens can be fixed with each other in  $90^\circ$  included position, at their sides in pairs altogether 6 various positions related to the centre of gyration. The tools are set turned away to one another on the working shaft in top view the circle is divided to  $30^\circ$  sectors. The container containing the abrasive medium can be put into an outer container in case of demand, which can be filled with cooling-heating water to the thermal dynamics of measuring procedure can be regulated.

The abrasive medium was 0/8 OK – type ballast stone. Its average aggregation density in dry condition is  $1,7 \text{ ton/m}^3$ . There is no practically clay-sludge content as it is produced from washed, granulated gravels by knapping. The grain fraction is between 2 and 8 mm.

The specimens to be in different radiuses move with various different peripheral speed in the abrasive medium and the height position results different surface pressure rations (Figure 7.) The abrasion tester makes possible exceptional complex evaluation in the function of these variables.

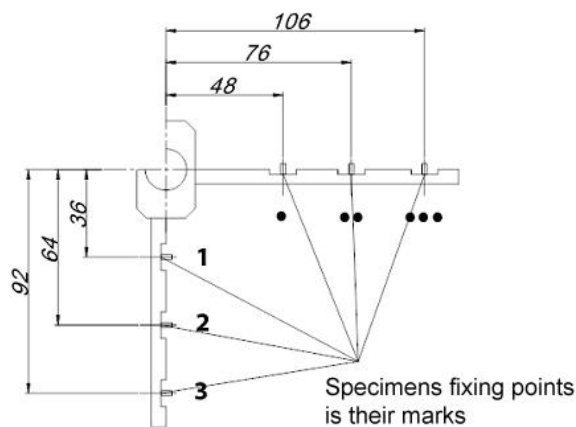

Figure 7. Position of specimens on different radiuses.

### 2.3. The abrasion and speed connection.

We have measured the abrasion of the 6 pcs. heat treated and 6 pcs. not heat treated specimens placed in all three levels (A,B,C) after seven various abrasion time.

The specimens covered different length with different peripheral speed moving on various radiuses. After averaging the abrasion results measured at each specimen, repeating three times the measuring series the same incline could be seen at the lines to be adaptable to the plot at heat treated and not heat treated specimens, too. Based on these the speed independence supposed were proved by mathematical – statistical methods, by covariance analyses at all three levels at heat treated and not heat treated specimens, too. The abrasion values of all specimens to be in the different levels can be presented with a single regression straight line.

This means that the abrasion values do not depend on the abrasive speed in the speed domain tested (Figure 8. and 9.). There is no significant difference between the specimens moved with various speeds but placed at the same level.

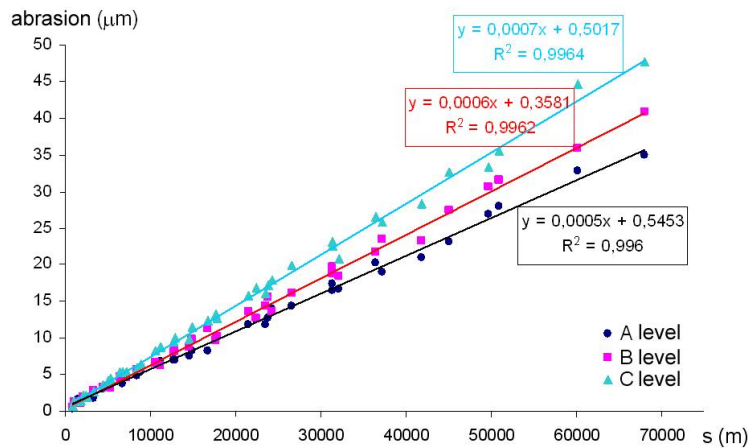

Figure 8. Abrasion values of heat treated specimens on “A”, “B” and “C” level ( $h_1$ ,  $h_2$  and  $h_3$  depth)

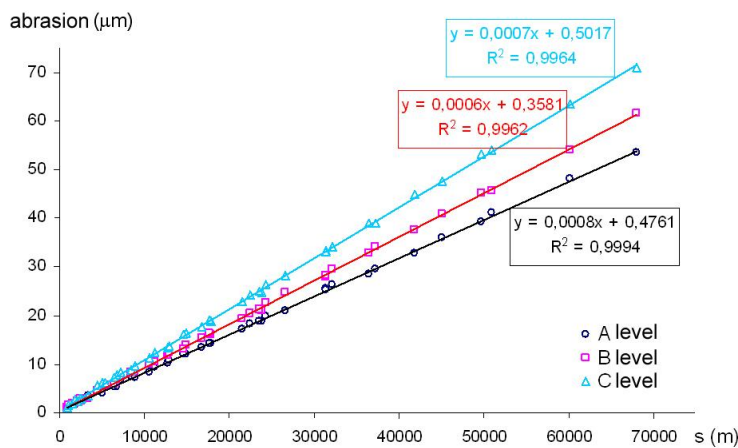

Figure 9. Not heat treated specimens abrasion values on “A”, “B” and “C” levels.

#### 2.4. Connection between surface load and abrasion

The specimens placed on the “A”, “B” and “C” level get different surface loads because of this the abrasion values measured on “A”, “B” and “C” levels has to be compared. According to the hypothesis the abrasion values depend on the load. It can be approximated with linear trend-line the appropriate data to different levels on the diagrams, the matching is close in each case. The data appropriate to different levels can be separated visibly however if there is significant difference between them it has to be examined by regression analysis. The worst case is where there is the smallest difference: this is the “A” and “B” level data of the specimens heat treated. The calculations carried out proved that there is significant difference between the abrasion values of specimens fixed on “A” and “B” level. This means that the amount of surface load has significant effect on the abrasion values in the system tested. In case of higher load the specimens have got higher abrasion.

#### 2.5. Comparing the layer structure of coating and abrasion values.

The abrasion measured as a resulting effect on the surface of specimens means the continuous decreasing of coatings with layer structure. In Figure 10. can be seen how changes the percentage rate of decisive chemical elements in certain layers of heat treated specimens. The chemical composition' changing does not influence the abrasion intensity. According to data tested by EDS spectroscopy the percentage rate of chemical elements in the layers of not heat treated specimens is formed otherwise, but this compound does not influence the abrasion intensity of certain layers.

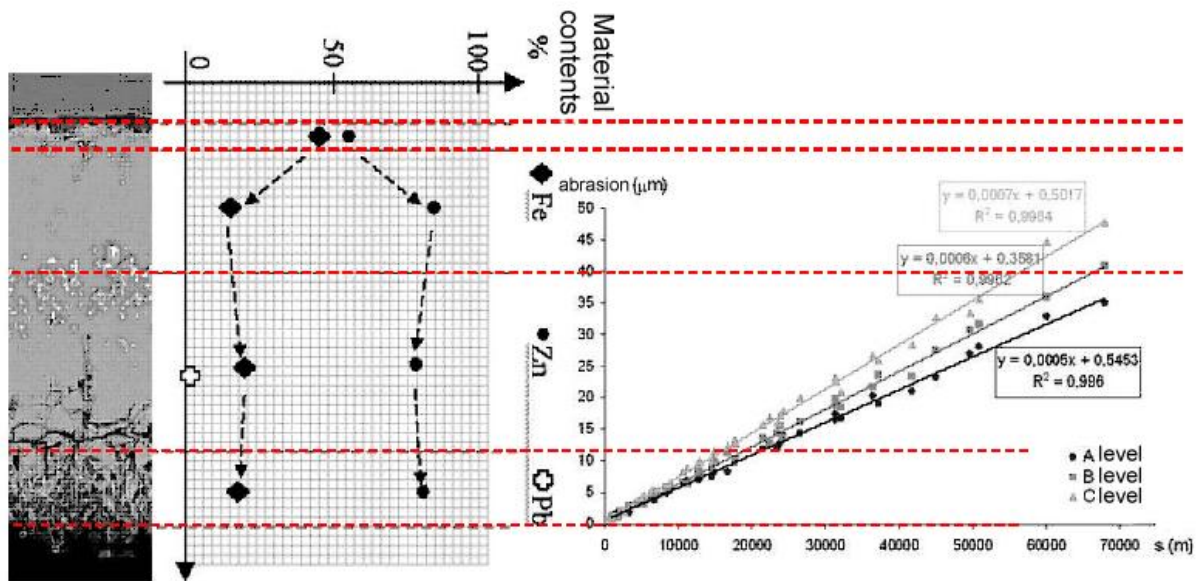

Figure 10. Heat treated specimens abrasion and the connection of layer structure.

### 3. CONCLUSION

- The multilayer coatings of hot-dip galvanized abrasion intensity in the test-system does not depend on the friction speed neither at heat treated nor at not heat treated specimens, but it depends on the medium pressure and on the resistance of medium deriving from that.
- The heat treatment improves the abrasive resistance. The higher hardness results higher abrasive resistance improvement.
- SEM-pictures and EDS spectroscopy proved that heat treatment results different gradient layer structure and composition.
- The linear abrasion dynamics of hot-dip galvanized layers tested does not depend on that, which layer comes to friction connection with abrasive medium. The inner gradient friction character did not effect the abrasion intensity measured, but the resultant of different gradient structure has different abrasive resistance.

### REFERENCES

1. Magyar Tűzhorganyzók szövetsége: Szakmai Ismeretek, Dunaújváros, Dunatáj Kiadó Kft., Dunaújváros, 1997
2. Dr. Zorkóczy Béla: Metallográfia és anyagvizsgálat, Tankönyvkiadó Budapest, 1975
3. Magyar Tűzhorganyzók szövetsége, Tűzhorganyzás, CD-kiadvány, 2008